

CROWN

Specifications

M Series

Walkie
Stackers

M

Series



Model 20M
Fork Over

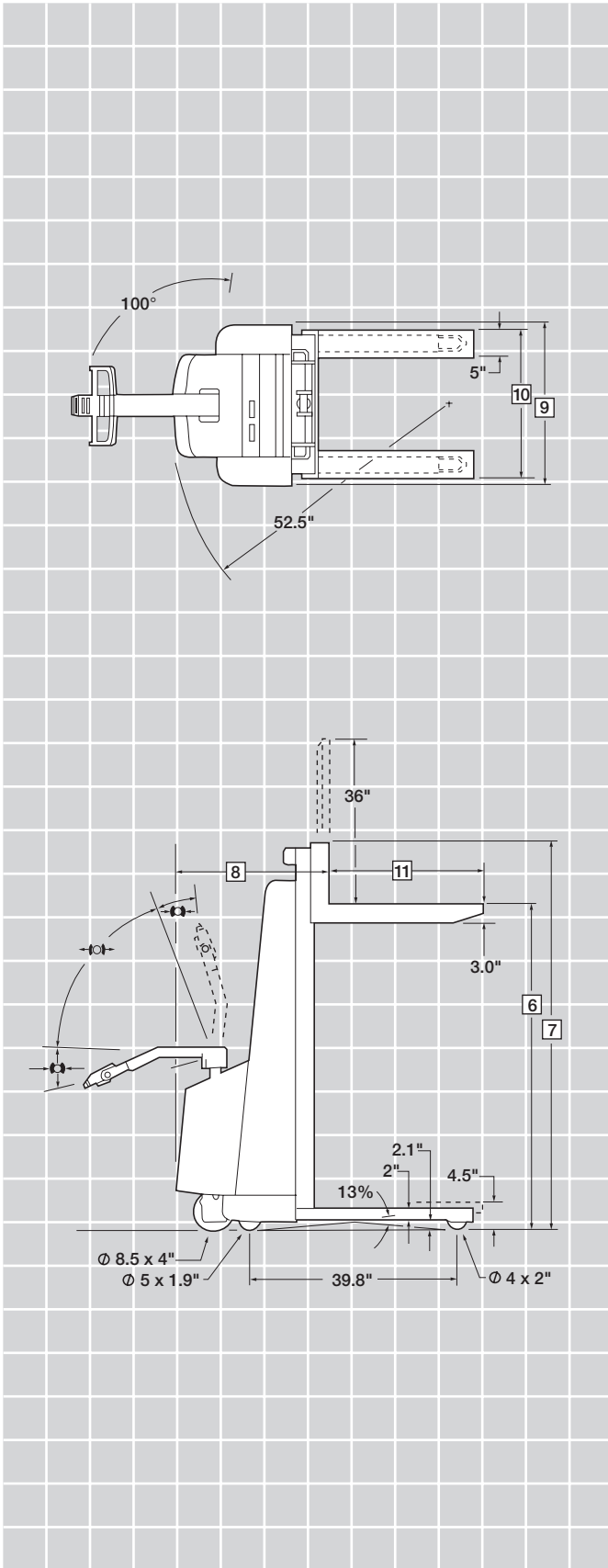

Model 20MT
Straddle

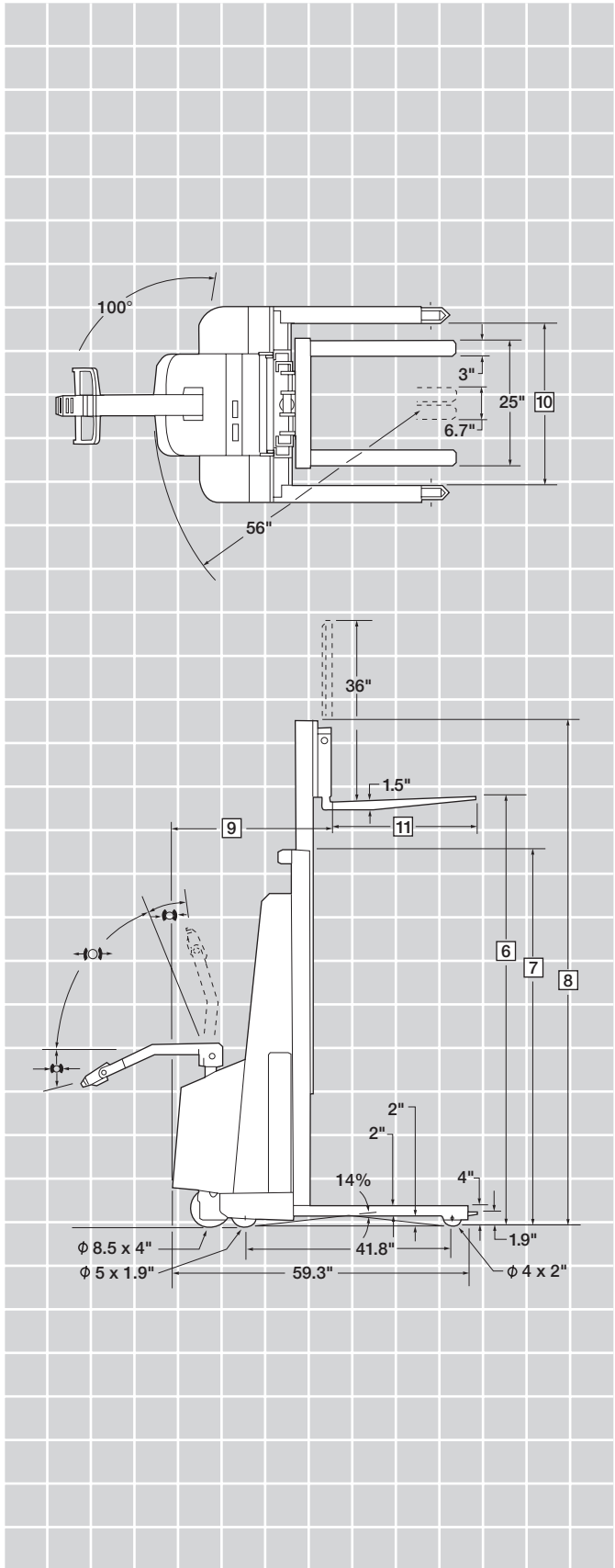

M Series

Specifications

1	Manufacturer	Crown Equipment Corporation			
2	Model	20M			
3	Load Capacity*	lb	2000		
4	Load Center	in	24		
5	Mast Type	Single			
6	Lifting Height	in	67		
7	Collapsed Height	in	78		
8	Head Length	in	28.5		
	Net Weight with Batteries	lb	990		
9	Overall Baseplate Width	in	26		
10	Inside/Outside Fork Spread	in	15.8/25.9		
11	Fork Lengths	in	30, 36, 42 and 48		
	Overall Length	in	Head Length (8) + Fork Length (11)		
12	Travel Speed	mph	Three forward and reverse speeds to 3 mph		
13	Lift Speed	E/L fpm	25/13		
14	Lowering Speed	E/L fpm	14/22		
2	Model	20MT			
3	Load Capacity*	lb	2000		
4	Load Center	in	24		
5	Mast Type	Telescopic			
6	Lifting Height	in	90	110	130
	Free Lift*	in	50	60	70
7	Collapsed Height	in	71.5	81.5	91.5
8	Extended Height**	in	106.5	126.5	146.5
9	Head Length	in	34.2	34.2	34.2
	Net Weight with Batteries	lb	1300	1400	1455
10	Inside Straddle	in	Adjustable in 2" increments from 32" to 50"		
	Outside Straddle	in	Inside plus 6.25"		
11	Fork Lengths	in	30, 36, 42 and 48		
12	Fork Adjustment	in	6.7 to 25		
13	Travel Speed	mph	Three forward and reverse speeds to 3 mph		
14	Lift Speed	E/L fpm	25/13		
15	Lowering Speed	E/L fpm	22/36		

* Attachments and longer load dimensions may result in derating of the capacity. Contact local dealer.

** Add 16.5" if optional load backrest is used.

M Series

Aisle Planning Guide

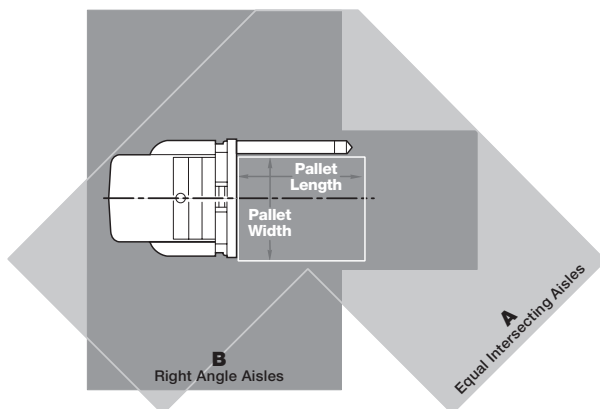

Straddling Load

Pallet Width		Pallet Length							
		30		36		42		48	
		A	B	A	B	A	B	A	B
30	in	55	64	59	64	62	66	65	71
36	in	59	65	62	66	65	69	68	72
42	in	64	68	66	69	69	71	71	74
48	in	69	72	70	72	72	74	74	77

Load Over Outriggers

Pallet Width		Pallet Length							
		30		36		42		48	
		A	B	A	B	A	B	A	B
30	in	50	63	54	64	57	66	60	68
36	in	53	64	57	65	60	67	63	69
42	in	58	65	62	67	64	68	67	70
48	in	64	66	67	68	68	70	70	72

Add 6" to all aisle dimensions for maximum maneuverability.

Capacity

Models 20M and 20MT
2000 lb at 24" load center

Batteries

Four 6-volt three cell, 17 plate (per cell) lead acid batteries - each rated at 100 amp hours at 20 hour rate, or 87 amp hours at six hour rate.

Charger

Built-in 120-volt 10 amp silicon rectifier type. Automatically tapers to trickle charge. Other charger's and voltages available.

Standard Equipment

1. 24-volt system
2. Crown manufactured heavy-duty contactors
3. Third speed cutout switch
4. Series wound high-torque drive and lift motor
5. Fused control and drive circuits
6. Power disconnect
7. Key switch
8. Plexiglass safety shield
9. Raise/lower buttons in control handle
10. Adjustable outriggers (MT only)

Optional Equipment

1. Load backrest
2. Polyurethane load, drive and caster wheels
3. Discharge meter
4. Hour meter
5. Semi-industrial battery and bench type charger complete with timer and SB 50 connector
6. Maintenance platform
7. Remote raise/lower
8. Snap-on platform
9. Wire mesh safety shield

Control Handle

Control handle with dual twist-grips which control three speeds forward and reverse. Twist-grips return to neutral when released. The handle provides 200° steering, and contains a large safety button which reverses the direction of the truck should the button touch the operator. A large horn button is standard equipment, as is a third speed cutoff switch.

Steering

Steering column is mounted on thrust and radial bearings for effortless steering. Steering handle can be turned 100° in either direction. Handle is spring loaded to return to vertical "brake on" position when released by operator.

Wheels and Tires

Steel caster wheels - 5" dia, 1.9" face. Steel load wheels - 4" dia, 2" face as standard. All wheels equipped with roller bearings. Drive tire - 8.5" x 4" x 4" standard pressed-on type rubber.

Hydraulic System

Heavy-duty motor with gear pump, check valve, relief valve and control valve. Flow control valve regulates lowering speed of forks. Lift cylinder with polyurethane packings. Oil reservoir with breather-filter to prevent foreign matter from entering hydraulic system. In-line suction filter to remove foreign matter from hydraulic circuit. Overload valve set to bypass oil to reservoir when system reaches maximum pressure.

Safety Switches

Third speed cutout switch may be used to shut off high speed when operating in congested areas. Third speed cutoff switch on telescopic models shuts off high speed when inner mast extends above "free lift" of forks. Safety interlock switch cuts off drive wheel power when service door is opened for charging and maintenance.

Drive Unit

Spur gear drive direct from motor to drive axle. Gear train is mounted on ball and tapered roller bearings operating in oil inside sealed gear housing. Housing is equipped with magnetic drain plug. Drive unit floats 2.5" to insure traction over uneven floors and on ramps. Heavy coil spring exerts 400 lb pressure on drive wheel for maximum traction.

Outriggers

Heavy steel construction with end contoured around load wheel. Each load wheel axle is rounded to prevent pallet damage.

Carriage Rollers

Alloy steel rollers contoured to fit mast and equipped with roller bearings. Telescopic units have adjustable side-thrust mast rollers.

Safety Shield

Clear high impact acrylic to help protect operator from chains and cylinder.

Lift Chain

Two alloy steel leaf-type chains

Finish

Beige and dark gray

Other Options

1. Audible travel alarm
2. Flashing lights

Safety considerations and dangers associated with audible travel alarms and flashing lights include:

- Multiple alarms and/or lights can cause confusion.
- Workers ignore the alarms and/or lights after day-in and day-out exposure.
- Operator may transfer the responsibility for "looking out" to the pedestrians.
- Annoys operators and pedestrians.

Dimensions and performance data given may vary due to manufacturing tolerances.

Performance is based on an average size vehicle and is affected by weight, condition of truck, how it is equipped and the conditions of the operating area. Crown products and specifications are subject to change without notice.



Crown Equipment Corporation
New Bremen, Ohio 45869 USA
Tel 419-629-2311
Fax 419-629-3796
crown.com

Because Crown is continually improving its products, specifications are subject to change without notice.

Crown and the Momentum symbol are trademarks of Crown Equipment Corporation.

Copyright 2002-2004 Crown Equipment Corporation
SF14109 Rev. 5/04
Printed in U.S.A.