

Model **PTB**

Advantages:

- Integrated pump without welding, no any leaking problems.
- Frame force is more reasonable, and the strength is more reliable.
- Handle seat has hole it is more convenient for installation of control chain.
- Forks lowering speed is controllable, with overload valve to avoid overloading.



Standard with entry & exist Roller
(option with single or double fork rollers)

Option:

- 1) steering wheel 200mm (fork wheel 80mm) are available.
- 2) Nylon wheel, polyurethane wheel, rubber wheel, single fork roller or tandem fork rollers.
- 3) Fork length: 800mm, 900mm, 1000mm, 1100mm.
- 4) Foot pedal release.
- 5) Pump color: black painting.
- 6) Quick lift (double speed lifting)



Conforms to EN ISO3691-5
Based on Directive 2006/42/EC

Model		PTB	
Capacity	Q(kg)	2500	2500
Lowered fork height	h ₁₃ (mm)	85	75
Steering wheel	mm	φ180	φ180
Fork wheel single	mm	φ74x93	φ74x93
Fork wheel double	mm	φ74x70	φ74x70
Max. lifting height	h ₃ (mm)	195	185
Height of tiller in drive position min./max.	h ₁₄ (mm)	1214	1214
Overall length	l ₁ (mm)	1543/1613	1543/1613
Fork length	l(mm/)	1150/1220	1150/1220
Width Overall forks	b ₅ (mm)	520/550/685	520/550/685
Ground clearance, center of wheelbase	m ₂ (mm)	32	22
Aisle width for pallets 1000x1200 crossways	Ast (mm)	1743/1813	1743/1813
Aisle width for pallets 800x1200 lengthways	Ast (mm)	1793/1813	1793/1813
Turning radius	Wa (mm)	1276/1346	1276/1346
Service weight	kg	56/70	56/70

Remark: Special size fork width and length can be made according to customer's requirement.

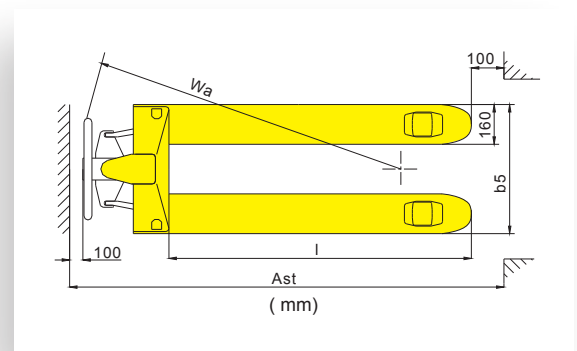
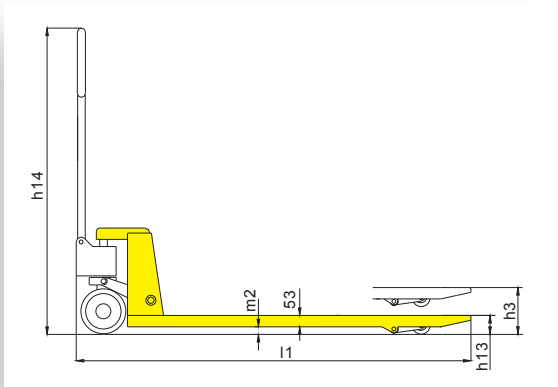

Rubber wrapped handle



Integrated cast pump