

Model **WPC15W - 18W**

AC
Function



product
design
award



red dot
design award

**MINI SERIES
ELECTRIC PALLET TRUCK**



- ✓ **Super Light**
- ✓ **Max. Compact**
- ✓ **Great Powerful**



Conforms to EN ISO3691-1
EN1175-1
EN16307-1
Based on Directive 2006/42/EC

The Mini type full electric pallet truck is with compact design and powerful motor, with small turning radius offers same outside as Manual pallet truck, widely used in narrow aisle workshop, super market and cargo containers.

Model WPC20W

AC
Function



Multi-function display



CURTIS Handle



Frei tiller head (option)



Advantages:

(CBD15W/CBD18W/CBD20W)

- With smallest turning radius 1320mm-1389mm (width 520mm/550mm/685mm).
- DC Brushless motor with high electric efficiency, maintenance free.
- Full sealed battery free to maintain big capacity 80AH fit for high intensity use.
- Max speed limit button can release brake when handle upright position, reduce turning space greatly. (option for Germany frei handle)
- High travel speed is up to 5.3-5.8km/h, improve productive efficiency.
- Floating balance wheel supports automatic height-adjusting.
- Horizontal drive wheel provides convenient replacement.

Standard Features:

- RUYI new type Tiller Head with Max. speed limit button.
- Emergency stop & belly button.
- BDI and hour meter.
- Casters to balance stability.
- Sealed battery.
- Brushless Horizontal motor.
- Built-in Charger.
- Exist roller.

Option

- Germany FREI Tiller Head.
 - Built-out charger.
- Fork width and length (size).
 - Load backrest.

Turning Radius

Smallest turning radius in MINI type electric pallet truck, it processes the smallest turning radius when switch to low speed. It adapts to use in narrow space, e.g. in the container.

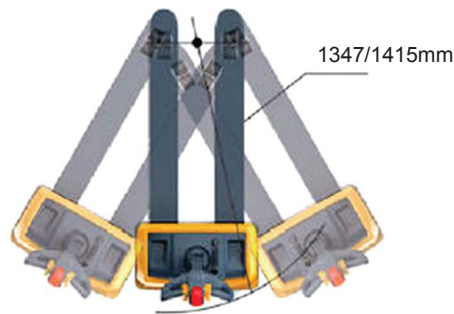

MINI type Electric Pallet Truck turning radius

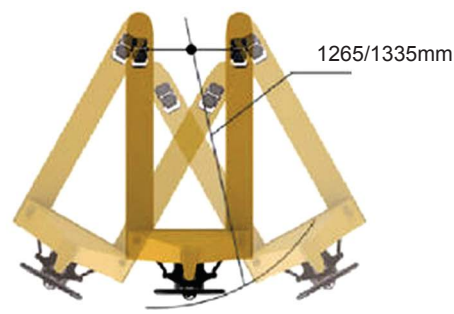

Hand Pallet Truck turning radius

Model		WPC15W	WPC18W	WPC20W
Load capacity	Q(kg)	1500	1800	2000
Load centre distance	c(mm)	600	600	600
Fork height, lowered	h13(mm)	85 / 75	85 / 75	85 / 75
Tyre size, front	mm	Φ195x70	Φ195x70	Φ195x70
Tyre size, rear (single)	mm	Φ80x93 / Φ74x93	Φ80x93 / Φ74x93	Φ80x93 / Φ74x93
Tyre size, rear (double)	mm	Φ80x70 / Φ74x70	Φ80x70 / Φ74x70	Φ80x70 / Φ74x70
Wheels, number front rear (x=driven wheels)		1X-2/4	1X-2/4	1X-2/4
Max. Lift height	h3(mm)	190/180	190/180	190/180
Height of tiller in drive position min./max.	h14(mm)	950/1310	950/1310	950/1310
Overall length	l1(mm)	1525/1595	1525/1595	1525/1595
Length to face of forks	l2(mm)	375	375	375
Overall width	b1(mm)	685	685	685
Fork dimensions	s/e/l(mm)	53/160/1150(1220)	53/160/1150(1220)	53/160/1150(1220)
Width overall forks	b5(mm)	520/550/685	520/550/685	520/550/685
Aisle width for pallets 1000×1200 crossways	Ast(mm)	1725/1795	1725/1795	1725/1795
Aisle width for pallets 800×1200 lengthways	Ast(mm)	1775/1795	1775/1795	1775/1795
Turning radius	Wa(mm)	1347/1415	1347/1415	1335/1405
Travel speed, laden/unladen	Km/h	5.3/5.8	4.5/5	4/4.5
Battery voltage,nominal capacity K20	V/Ah	24/105	24/105	24/105
Battery dimensions l/w/h	mm	260/169/215	260/169/215	260/169/215
Battery weight	kg	49	49	49
Service weight (with battery)	kg	240	250	250

