



Designed for fast single- and dual-cube handling.

Increases productivity by providing efficient single- and dual-cube handling.

APPLICATIONS

Handles single or dual concrete cubes safely and efficiently using a variety of fork lengths and spacing to fit any cube handling application. Single sideshifting models allow accurate positioning on single unit loads. Dual independent sideshifting models offer accurate fork positioning and greater stability, so operators can pick dual cubes separately, then sideshift them together for stable transportation.

FEATURES

- Utilizes our proven high-visibility sideshifters, which are no-weld mounted, allowing for easy re-positioning
- “Over-center” sideshift standard for easy truck loading
- Heavy-duty structural frame
- Protected bearing segments with easily accessible grease fittings
- Heavy-duty cylinders with case-hardened and chromed rods for long life in outdoor operations
- Self-cleaning cylinder rods
- Floating-eye forks

MODELS

Single Sideshifting Block Handler

- 6, 8 or 12 forks
- 9,000 to 15,000 pound capacity

Dual Sideshifting Block Handler

- 12 or 16 forks
- 10,000 to 15,000 pound capacity



Single

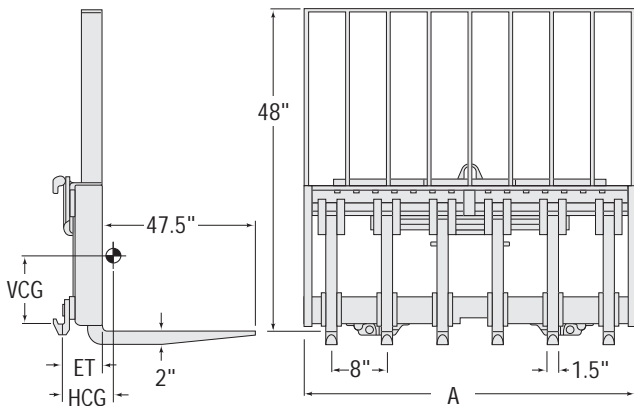

Dual

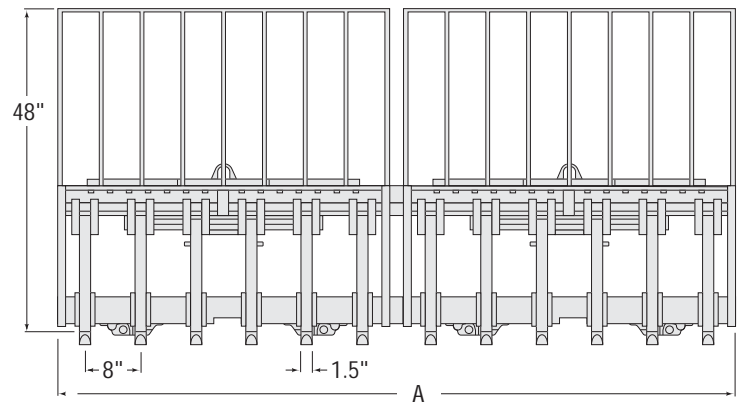

Catalog Order No.	Capacity @ 24" (600 mm) Load Center		Truck/Sideshift Mtg. Class	Weight		Number of Forks	Effective Thickness ET	Horizontal Ctr. of Gravity HCG	Vertical Ctr. of Gravity VCG	Carriage Width A	Total Sideshift	Min. Truck Carriage Width
	lbs	kg		lbs	kg							
Single Block Handlers												
100F-BSS-48	9,000	4,085	III	1,095	497	6	5"	7.5"	9.2"	48"	8"	41"
100F-BSS-60	10,000	4,545	III	1,410	640	8	5"	7.8"	9.2"	60"	8"	48"
100F-BSS-96	10,000	4,540	III	1,720	781	12	5"	8"	9.3"	96"	8"	82"
150F-BSS-48	9,000	4,085	IV	1,235	561	6	5.3"	8.3"	13"	48"	12"	41"
150F-BSS-60	12,000	5,450	IV	1,555	706	8	5.3"	7.4"	12.9"	60"	12"	48"
150F-BSS-96	15,000	6,810	IV	2,100	953	12	6"	9.2"	8.5"	96"	12"	82"
Dual Block Handlers ④												
100F-BDS-96	10,000	4,540	IV③	2,645	1,201	12	8"	8.3"	9.6"	96"	12"	62"
100F-BDS-120	10,000	4,540	IV③	3,420	1,553	16	8"	8.2"	10.2"	120"	12"	80"
150F-BDS-96	15,000	6,810	IV③	3,370	1,530	12	8.6"	8.1"	13.1"	96"	12"	62"
150F-BDS-120	15,000	6,810	IV②	4,235	1,923	16	8.6"	8.1"	13.1"	120"	12"	80"

- ① False carriage is included with model.
- ② Integral or pin mount. Integral carriages do not include load rollers or attaching hardware.
- ③ Integral mounting available for higher net truck capacity.
- ④ Dual Block Handlers require two installation kits.
- ▶ Special options including; non-standard frame widths, variable fork length, custom load backrests (48" standard) and spacing and special fork and attachment mounting available. Consult Cascade.

OPTIONS

- Nonstandard frame width
- Variable fork length and spacing
- Variable type of fork mounting (floating eye standard)
- Load backrests (48" standard)
- Integral or pin mounting
- Quick-Disconnect mounting kit