



An economical solution for handling multiple pallets with a single attachment

A cost effective, solution to increase pallet handling productivity..

APPLICATIONS

The Double Wide Fork Positioner is recommended for distribution, warehousing and manufacturing operations. This attachment will excel in open area applications as well as trailer loading operations that routinely allow the handling of two pallets at a time. This high visibility fork positioner allows a clear line of site over and through the attachment giving the operator increased awareness of the fork tips. The Double Wide Fork Positioner can handle a single pallet, or by spreading the forks hydraulically, carry two pallets side by side.

FEATURES

- Excellent operator visibility
- No-Weld Installation
- Zinc plated, corrosion resistant components
- Uses standard 3" forks

OPTIONS

- Bronze bearings
- Bronze lower hooks
- Custom Load Backrest heights
- Non-Sideshifting units available
- Solenoid Valve Hydraulic Control
- Radio Frequency Hydraulic Control
- 4" or 5" forks



DOUBLE WIDE FORK POSITIONER

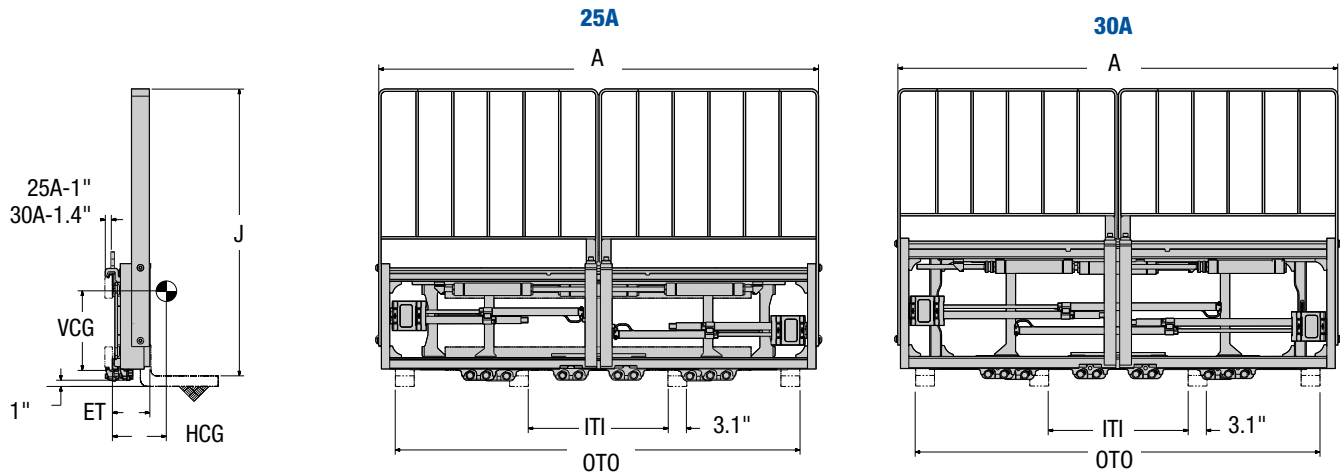

Fork Positioners

Catalog Order No.	Capacity @ 24" (600 mm) Load Center		Mtg. Class	Total Sideshift	Weight		Min. Truck Carriage Width	Overall Width Extended	Effective Thickness	Horizontal Ctr. of Gravity	Vertical Ctr. of Gravity	Backrest Height	Out To Out Range	In To In Range
	lbs	kg			lbs	kg		A	ET	HCG	VCG	J	OTO	ITI
36" x 36" Beverage Pallets														
25A-FPD-A005	5,500	2,500	II	8"	682	314	51.2"	85.8"	4.6"	3.1"	14.6"	48"	80" - 26"	32" - 12"
30A-FPD-B005	6,500	3,000	III	8"	802	364	51.2"	85.8"	5.0"	3.3"	16.5"	48"	80" - 26"	32" - 12"
48" x 40" Block and GMA Pallets														
25A-FPD-A221	5,500	2,500	II	8"	712	323	48.8"	88.4"	4.6"	3.1"	14.6"	48"	83" - 28"	28" - 13"
30A-FPD-B221	6,500	3,000	III	8"	827	375	48.8"	88.4"	5.0"	3.3"	16.1"	48"	83" - 28"	28" - 13"

- ▶ Right hand termination forks open/close, left hand sideshift, opposite terminations available at no charge.
- ▶ Does not include forks.
- ▶ FPD units limited to forks up to 60" in length

Installation Kit

Catalog Order No.	Type
6814307	#8 JIC/ORFS High Term
6814308	#6 JIC/ORFS High Term
6814309	Hose Reel

Adaptable Carriage

Allows mounting a 25A or 30A FPD on a narrower carriage.

Catalog Order No.	Minimum Truck Carriage Width	Weight	Horizontal Ctr. of Gravity	Vertical Ctr. of Gravity	Effective Thickness
30A34163 ①	34.6"	235	.8"	11.4"	2.2"
25A34081 ②	34.6"	185	.8"	8.7"	2.0"
25A34164 ③	34.6"	240	.8"	11.4"	2.5"

- ① A class 3 unit 51.1" wide usable carriage to fit onto a 34.6" minimum truck carriage width.
- ② A class 2 unit 51.1" wide usable carriage to fit onto a 34.6" minimum truck carriage width.
- ③ A jump carriage with Class 2 on the truck side, and Class 3 on the attachment side. 51.1" mm usable carriage to fit onto a 34.6" minimum truck carriage width.

Fork Set Options

Includes four forks designed for this attachment.

Catalog Order No.	Blade Length
Class 2	
6814297	36"
6814298	42"
6814299	48"
6814300	54"
6814301	60"
Class 3	
6814302	36"
6814303	42"
6814304	48"
6814305	54"
6814306	60"

Hydraulic Functions

Hydraulic Functions	Truck Aux. Valves Required
2	2

Cascade Corporation • PO Box 20187 • Portland, OR 97294-0187 • USA • 800 CASCADE (227.2233) • Tel 503.669.6257 • Fax 800.693.3768 • Fax 503.669.6367
 Cascade Canada Ltd. • 5570 Timberlea Blvd. • Mississauga, Ontario L4W 4M6 • Canada • 800.380.2272 • Tel 905.629.7777 • Fax 905.629.7785