



## A versatile attachment ideal for agriculture and food processing.

### APPLICATIONS

Designed to provide the agricultural, food processing, and manufacturing markets an efficient and economical means of handling and dumping bins. Can easily accommodate various bin heights by manually adjusting the top bin stops.

### MODELS

- 46 inch wide
- 48 inch wide
- 60 inch wide
- 72 inch wide

### FEATURES

- Heavy duty construction
- Fast, smooth, forward dumping motion
- Unsurpassed visibility
- Proven Cascade quality
- 130° forward tilt
- Adjustable bin heights
- Simplified hydraulics
- Common Cascade parts available worldwide
- Low effective thickness resulting in increased net truck capacity



*Built for fast, efficient, and productive handling of agricultural and other bins.*

# FORWARD BIN DUMPER

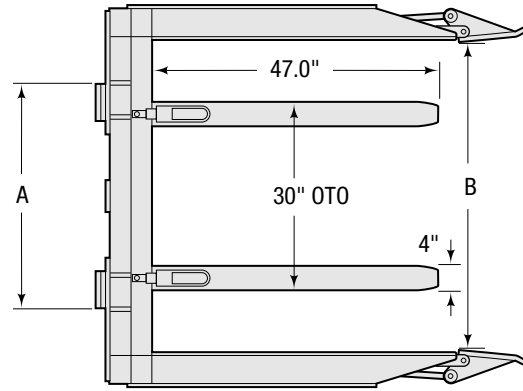
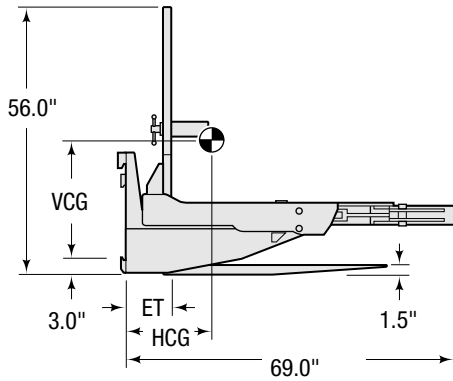

Catalog Order No.	Capacity @ 24" (600 mm) Load Center		Mtg. Class	Weight		Effective Thickness ET	Horizontal Ctr. of Gravity HCG	Vertical Ctr. of Gravity VCG	Min. Truck Carriage Width A	Bin Dimensions DxWxH	Inside of Arms B
	lbs	kg		lbs	kg						
30D-FBB-48A	3,000	1,360	II	1,060	480	9.4"	18.4"	7.8"	36"	48" x 48" x 24"-54"	50.25"
30D-FBB-48B	3,000	1,360	III / II	1,083	490	9.4"	18.1"	4.1"	36"	48" x 48" x 24"-54"	50.25"
40D-FBB-46A	4,000	1,815	II	1,390	631	9.5"	14.0"	7.0"	36"	46" x 46" x 24"-48"	48.25"
40D-FBB-46B	4,000	1,815	III	1,390	631	9.5"	14.0"	7.0"	36"	46" x 46" x 24"-48"	48.25"
40D-FBB-48A	4,000	1,815	II	1,390	631	9.5"	14.0"	7.0"	36"	48" x 48" x 24"-48"	50.25"
40D-FBB-48B	4,000	1,815	III	1,390	631	9.5"	14.0"	7.0"	36"	48" x 48" x 24"-48"	50.25"
40D-FBB-60A	4,000	1,815	II	1,480	672	9.5"	14.0"	7.0"	42"	48" x 60" x 24"-48"	62.25"
40D-FBB-60B	4,000	1,815	III	1,480	672	9.5"	14.0"	7.0"	42"	48" x 60" x 24"-48"	62.25"
40D-FBB-72A	4,000	1,815	II	1,570	713	9.5"	14.0"	7.0"	42"	48" x 72" x 24"-48"	74.25"
40D-FBB-72B	4,000	1,815	III	1,570	713	9.5"	14.0"	7.0"	42"	48" x 72" x 24"-48"	74.25"

- ▶ Bolt-On mounting is standard on Forward Bin Dumpers. Quick-disconnect mounting is available at no charge.
- ▶ Larger capacities are available, consult Cascade.

## Options

- Quick-Disconnect mounting
- Class II or Class III mounting
- Custom bin dimensions
- Extended capacities
- Sideshifting

## INSTALLATION KIT

Catalog Order No.
659245

## HYDRAULIC FLOW AND PRESSURE

Minimum Flow	Recommended Flow	Maximum Flow	Maximum Pressure PSI
5 GPM	7.5 GPM	10 GPM	2,300

## HYDRAULIC FUNCTIONS

Hydraulic Functions	Truck Auxiliary Valves Required
1	1

## MOUNTING CLASS INFORMATION

Mounting Class	Truck Capacity
II	2,000-5,500 lbs.
III	6,000-10,000 lbs.